

H80 INOX -A90° ML1P - DATA SHEET

BUNDLE MACHINE RANGE:

Product Dimensions	Min÷Max (mm)
A-Length	140÷500 (mm)
B-Width	150÷600 (mm)
H-Height	70÷370 (mm)

PRODUCT MACHINE RANGE:

Product Dimensions	Min÷Max (mm)
A-Length/D-Diameter	
2 Rows	70÷200 (mm)
3 Rows	70÷135 (mm)
4 Rows	70÷102 (mm)
B-Width/D-Diameter	70÷600 (mm)
H-Height	70÷370 (mm)

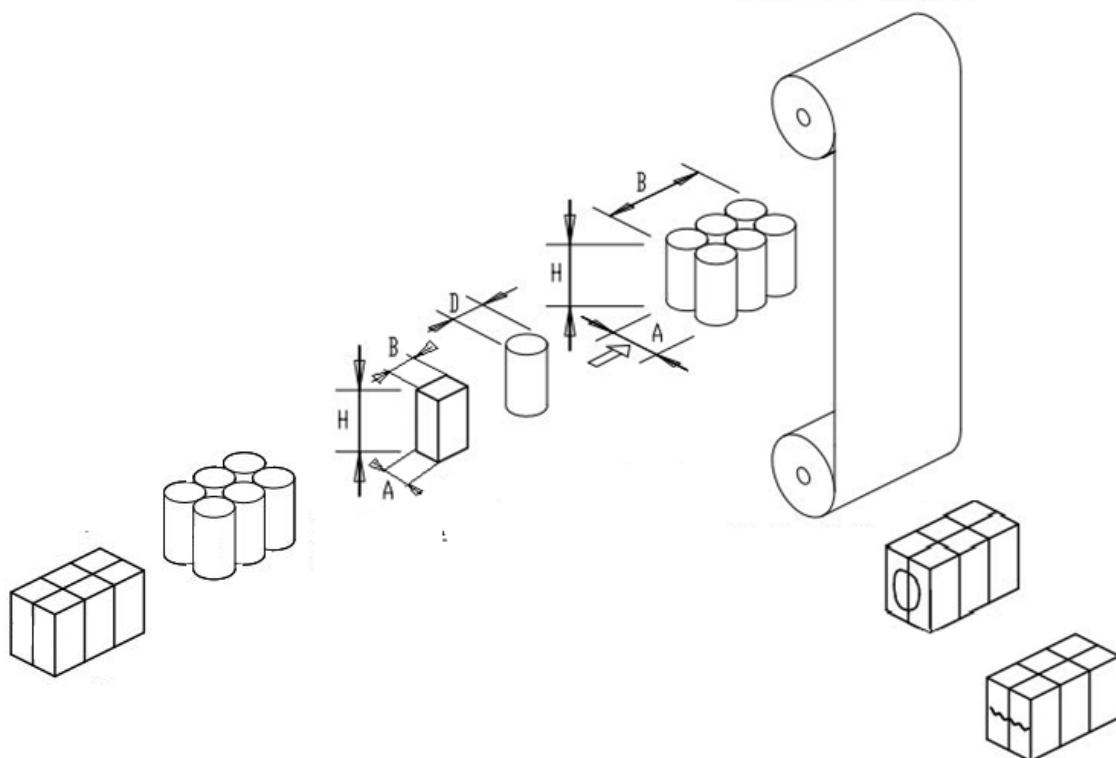



DIMENSIONAL RATIO TO BE RESPECTED:

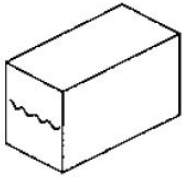

Total closure with flap overlap

$B + (2/3 H) \times 2 \text{ max} < 800 \text{ mm Film Reel Width}$

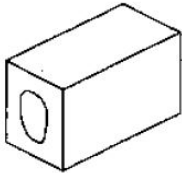

Closure with side openings

$B + H \text{ max} < 800 \text{ mm Film Reel Width}$

N.B. For irregularly shaped products, MacDUE reserves the right to verify the feasibility and to list any possible additional costs.

Packaging Material:

Neutral, pre-perforated and shrinkable Polyethylene Film with thickness of 20-50 μm . Flat film reel.

Maximum weight acceptable by the machine: 20 Kg. per linear meter

MAX Temperature: 215°C

Shrink tunnel conveyor speed: MIN 6,5 meters/minute – MAX 17 meters/minute

MAX production speed with neutral, pre-perforated and shrinkable Polyethylene Film with thickness of 40 micron: 10-12 bundles/min

The indicated speed is strictly related both to product characteristics and stability, to BUNDLE CONFIGURATION, packaging material and to the layout of the line. Therefore, final speeds will be confirmed into Mac Due Purchase Order document after careful evaluation by our engineering department of the products and packaging material actually used for the final packaging. Moreover, in case your production demands require a continuous run at the maximum speed, it is absolutely necessary to develop a layout of the line following the technical indications of MACDUE layout department.

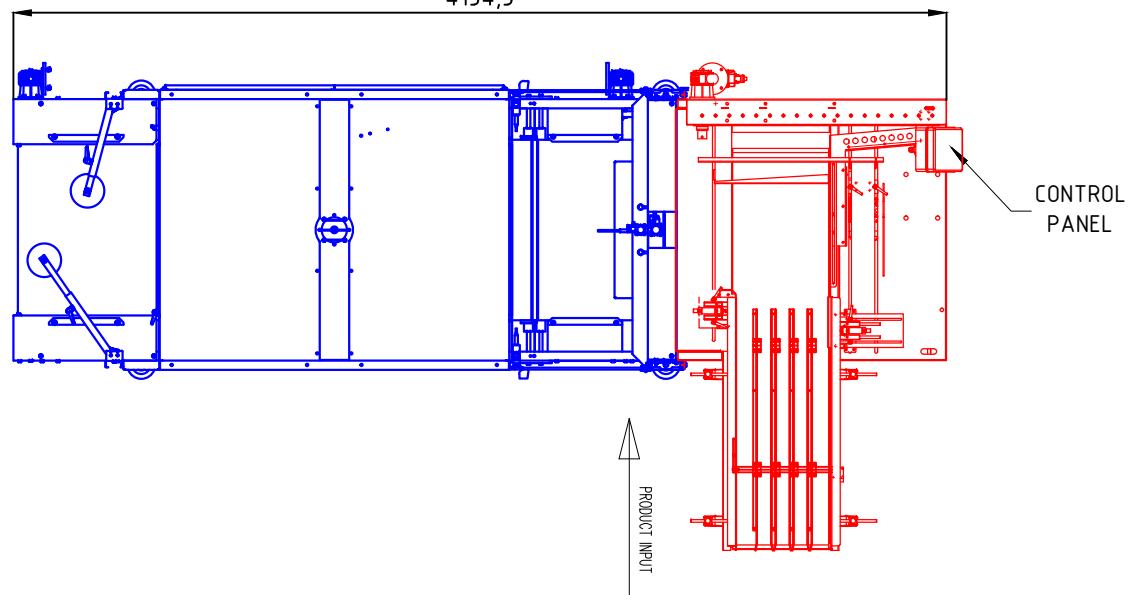
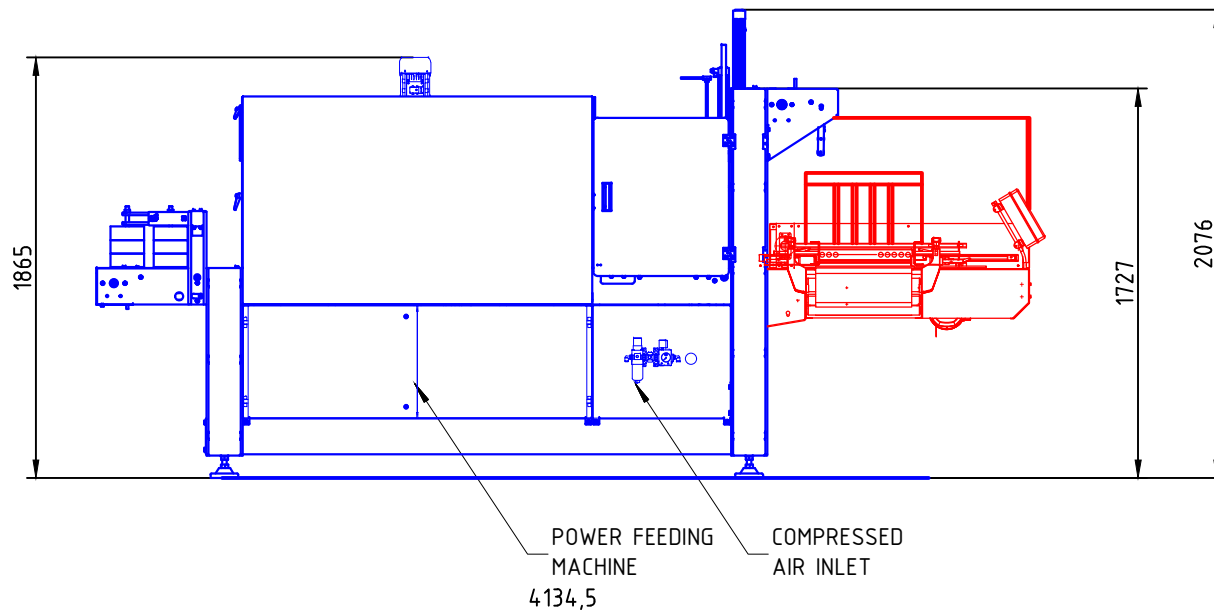
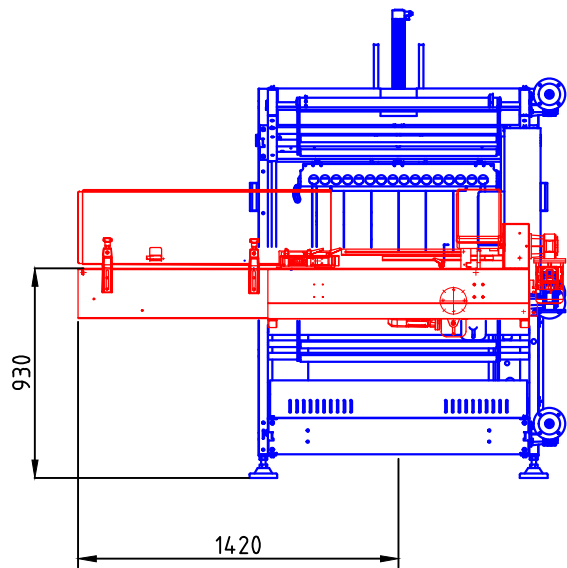

TECHNICAL SPECIFICATION	VALUE
WEIGHT	1100 Kg
POWER SUPPLY	400V. 50Hz 3/PE
MACHINED INSTALLER POWER	26kW
COMPRESSED AIR INLET	6 bar
PIPE CONNECTIONS	Ø8 mm
CONSUMPTION	25NI/cycle

	DOCUMENTO RISERVATO A TERMINI DI LEGGE CON DIVIETO DI RIPRODUZIONE QUOTE ESPRESSE IN: mm. NON IMPEGNATIVE.	SOSTITUITO DAL	SOSTITUISCE IL
	CLIENTE		
SCALA /	TIPO MACCHINA	H80 INOX ML1P	
DATA 23-04-20	IMPIANTO	N. DS.	IM5775
DISEGN. /			